



Shown with optional trailer

STANDBY 45 kW
PRIME 41 kW
60 Hz

Voltage	Standby kW (kVA)	Prime kW (kVA)
208/120V 3 phase	45 (56.3)	41 (51.3)
480/277V 3 phase	45 (56.3)	41 (51.3)
240/120V 1 phase	35 (35)	32 (32)

FEATURES

EPA TIER 3 AND CARB CERTIFIED FOR NON-ROAD MOBILE APPLICATIONS

SOUND ATTENUATED ENCLOSURE

- The fully weatherproof enclosure incorporates an internally mounted exhaust silencer and is of extremely rugged construction in order to withstand the rough handling common on many construction sites.
- Highly corrosion resistant construction.
 - Body made from sheet steel components pretreated with zinc phosphate prior to polyester powder coating at 200° C (392° F)
 - Black stainless steel padlockable latches.
 - Zinc die cast hinges/grab handles.
- Excellent access for maintenance.
 - Two large doors on each side. Two rear doors for distribution/control panel.
 - Front panel for air discharge box access.
 - Lube oil and cooling water drains piped to exterior of the enclosure.
- Security and safety.
 - Safety glass control panel viewing window in a lockable access door.
 - Cooling fan and battery charging alternator fully guarded.
 - Fuel fill and battery can only be reached through lockable access doors.
- Transportability.
 - Tested and certified single point lifting eye.
 - Lifting points on baseframe.

ROBUST DESIGN FOR RENTAL ENVIRONMENT

- Packages designed to survive in rugged environments.
- Single wall fuel tank base with 24 hour minimum fuel supply.

DISTRIBUTION PANEL

- Switchable voltage from 480/277V 3-phase to 240/139V 3-phase (Can be dialled down to 208/120V 3-phase) 240/120V single phase.*

REAR CUSTOMER ACCESS

- Separate control panel and distribution panel access doors.
- Hinged door over main bus connectors.
- Emergency stop on panel.
- Remote start/stop contacts.

ENVIRONMENTALLY FRIENDLY DESIGN

- EPA Tier 3 off-highway compliant engine.

OPTIONS

- AH1L – Anti-condensation heater 110-120 volt AC
- WHL – Coolant Heater 110-120 volt AC
- PBC3UL – UL Listed Battery Charger
- CSA – CSA certification
- FCUL2 – UL double walled fuel tank base
- Tandem axle trailers with hydraulic or electric brakes

* Refer to distribution panel specifications for details.

STANDARD FEATURES

1. ENGINE

Heavy duty industrial EPA Tier 3 compliant diesel engine.

1.1 Governor

Electronic, compliant with BS5514, Class A1.

1.2 Electrical System

12 volt DC. Energized to run shutdown solenoid. Oil pressure and coolant temperature/level shutdown switches and gauge senders.

1.3 Derates

Genset power derates will be required in accordance with engine manufacturers above 42° C (107° F).

2. COOLING RADIATOR

Radiator and cooling fan complete with protection guards, designed to cool the engine in ambient temperatures up to 43° C (109° F).

3. ENGINE FILTRATION SYSTEM

Cartridge type dry air filters with restriction indicator. Racor fuel filter in addition to engine filter. Cartridge type fuel filters and full flow lube oil filters. All filters have replaceable elements.

4. EXHAUST SYSTEM

Critical Silencer with flexible connector with vertical discharge.

5. ELECTRICAL SYSTEM

12 volt system with 65A battery charging alternator, and starter motor on engine. Single 12V Cat brand maintenance free battery, battery rack and cables mounted on the generator set baseframe optional battery charger mounted on control panel.

6. GENERATOR

Screen protected and drip-proof, self exciting, self-regulating brushless generator with fully interconnected damper windings, IC06 cooling system and sealed-for-life bearings. Switchable voltage output.

6.1 Insulation System

The insulation system is Class H. Windings are impregnated in a triple dip thermo-setting moisture, oil and acid resisting polyester varnish. Heavy coat of anti-tracking varnish for additional protection against moisture or condensation.

6.2 Electrical Characteristics

Electrical design in accordance with BS5000 Part 99, IEC60034-1, EN61000-6, NEMA MG-1.22.

6.3 Automatic Voltage Regulator (AVR)

The fully sealed R438 automatic voltage regulator maintains the voltage within the limits of $\pm 0.5\%$ at steady state from no load to full load.

Nominal adjustment is by means of a trimmer incorporated in the AVR. The panel door incorporates an additional voltage adjustment potentiometer.

6.3.1 Permanent Magnet Generator

Providing 350% short circuit capabilities, enhanced motor starting and non-linear loading performance.

6.4 Waveform Distortion, THF and TIF Factors

The total distortion of the voltage waveform with open circuit between phases or phase and neutral is in the order of 1.8. On a 3-phase balanced harmonic-free load the total distortion is 4%. Machines are designed to have a THF less than 2% and a TIF less than 50. A 2/3 pitch factor is standard on all stator windings.

6.5 Radio Interference

Suppression is in line with the provisions of EN61000-6.

7. MOUNTING ARRANGEMENT

7.1 Baseframe

The complete generator set is mounted on a heavy duty fabricated steel baseframe. The baseframe includes an integral fuel tank base incorporating specially designed lifting points.

7.2 Coupling

The engine and generator are directly coupled by means of an SAE flange so that there is no possibility of misalignment after prolonged use. The engine flywheel is flexibly coupled to the generator rotor and a full torsional analysis has been carried out to guarantee no harmful vibration will occur in the assembly.

7.3 Anti-Vibration Mounting Pads

Captive anti-vibration pads are affixed between engine/generator feet and the baseframe ensuring complete vibration isolation of the rotating assemblies.

7.4 Safety Guards

The fan, fan drive and battery charging generator drive are fully guarded for personnel protection. Heat guards protect personnel from the exhaust pipe. All guards are to OSHA standards.

8. FUEL SYSTEM

Fuel feed and return lines to the engine are terminated at the baseframe mounted 24 hour extended capacity fuel tank. 3-way valves to allow connection of auxiliary fuel tank.

9. CONTROL SYSTEM

9.1 Control Panel

Set mounted autostart panel in a vibration isolated NEMA 1 sheet steel enclosure with a hinged lockable door.

9.2 DC and AC Wiring Looms

DC and AC wiring looms utilizing industrial type multi-pin connectors to permit fast fault finding.

10. DISTRIBUTION PANEL

10.1 Circuit Breaker

3-pole UL CSA listed molded case circuit breaker mounted on the generator set in a vibration isolated NEMA 1 distribution panel.

10.2 Multiple Power Receptacles

Receptacles accept industry standard male plugs. Each receptacle is protected by a miniature circuit breaker which also acts as an on/off switch.

11. DOCUMENTATION

A full set of operation and maintenance manuals, circuit wiring diagrams, and instruction leaflets is provided.

12 SOUND ATTENUATED ENCLOSURES

A noise reducing enclosure surrounds the entire generator set. Combined with a critical engine silencer this provides an overall noise reduction from 65 to 68 dBA at 23 feet through the range.

13. FACTORY TESTS

The generator set is load tested before dispatch. All protective devices, control functions and site load conditions are simulated and the generator and its systems checked, proved and then passed for dispatch. A test certificate can be provided upon request.

14. EQUIPMENT FINISH

All sheet metal components including the enclosure and the base tank are fully degreased, phosphated and chromated for anti-corrosive protection prior to painting with polyester powder. The powder is cured at a temperature of 200° C (392° F) to ensure maximum scuff resistance and durability. All fasteners are electroplated. The engine and generator are thoroughly cleaned and finished in temperature controlled ovens with industrial high gloss polyurethane paint.

15. STANDARDS

The equipment meets the following standards: BS4999, BS5000, BS5514, IEC60034, EN61000-6, NEMA MG-1.22.

16. WARRANTY

Full manufacturer's warranty.

XQ45

Materials and specifications are subject to change without notice.

Generator Set Technical Data – 1800 rpm/60 Hz			Standby		Prime	
Power Rating	kW	(kVA)	45	(56.3)	41	(51.3)
Lubricating System Oil type required: API CH-4						
Total oil capacity	L	(U.S. gal)	8.4	(2.2)	8.4	(2.2)
Oil pan	L	(U.S. gal)	6.9	(1.8)	6.9	(1.8)
Fuel System Recommended fuel: #2 diesel						
Generator set fuel consumption						
100% load	L/hr	(gal/hr)	15.7	(4.1)	14.3	(3.8)
75% load	L/hr	(gal/hr)	12.0	(3.2)	11.1	(2.9)
50% load	L/hr	(gal/hr)	8.9	(2.4)	8.3	(2.2)
Fuel tank capacity	L	(U.S. gal)	595	(157.2)	595	(157.2)
Cooling System Radiator system capacity including engine	L	(U.S. gal)	13.0	(3.4)	13.0	(3.4)
Air Requirements Combustion air flow	m ³ /min	(cfm)	5.1	(180)	5.0	(177)
Maximum air cleaner restriction	kPa	(in H ₂ O)	8.0	(32.1)	8.0	(32.1)
Radiator cooling air	m ³ /min	(cfm)	101.4	(3,581)	101.4	(3,581)
Generator cooling air	m ³ /min	(cfm)	19.2	(678)	19.2	(678)
Exhaust System Exhaust flow at rated kW	m ³ /min	(cfm)	13.7	(484)	12.8	(452)
Exhaust temperature at rated kW – dry exhaust	°C	(°F)	571	(1060)	532	(990)
Generator Set Noise Rating* [with enclosure at 7 meters (23 feet)]	dBA		63.8		63.5	

SPECIFICATIONS

GENERATOR

Voltage regulation ± 0.5% at steady state
from no load to full load
Frequency ± 0.25% for constant load from
no load to 100% load
Waveform distortion THD < 4%
Radio interference Compliance with EN61000-6
Telephone interference TIF < 50, THF < 2%
Overspeed limit 2250 rpm
Insulation Class H
Temperature rise Within Class H limits
Available voltages Switchable voltage
output: 480/277 volt,
240/139 volt 3-phase to
240/120 volt single phase
Deration Consult factory for available outputs
Ratings At 30° C (86° F), 152.4 m (500 ft)
60% humidity, 0.8 pf

ENGINE

Manufacturer Caterpillar
Model C 4.4
Type 4-cycle
Aspiration Turbocharged
Cylinder configuration In-line 4
Displacement – L (cu in) 4.4 (269)
Bore – mm (in) 105 (4.13)
Stroke – mm (in) 127 (5.00)
Compression ratio 18.2:1
Governor
Type Electronic
Class ISO8528 G1 and G2
Piston speed – m/sec (ft/sec) 7.62 (25.0)
Engine speed – rpm 1800
(Figs. are dep. on the Governor class) G2
Maximum power at rated rpm – kW (hp)
Standby 64 (86)
Prime 58 (78)
BMEP – kPa (psi)
Standby 970 (140.7)
Prime 879 (127.5)

CONTROL PANEL

- A** NEMA 1 steel enclosure with hinged lockable door with viewing window.
- B** Manual run/off.
- C** Panel light ON/OFF switch.
- D** Separate pre-heat pushbutton.
- E** Red emergency stop pushbutton.
- F** Lamp test/reset pushbutton.
- G** AC instrumentation: 1-voltmeter, 1-ammeter, 1-frequency meter.
- H** Engine gauges for: oil pressure, coolant temperature, battery volts, fuel level.
- I** Fuel level display with momentary activation pushbutton.
- J** Hours run meter.
- K** Voltage adjust potentiometer.
- L** Frequency adjust potentiometer.
- M** 1 — 7 Position voltmeter phase selector switch.
- N** 1 — 4 Position ammeter phase selector switch.

OTHER FEATURES

- Shutdowns: high coolant temperature/low coolant level, low oil pressure, overcrank, overspeed.
- Low fuel level/fuel tank leak alarm.
- Printed circuit board control logic.
- Autostart standard.
- Cycle cranking with 3 adjustable time crank/rest periods.
- Battery charger, 5 Amp constant voltage, UL listed (optional).

DISTRIBUTION PANEL

- 1** 1 — 3 Pole MCCB with solid neutral (4 Wire). UL/CSA listed with shunt trip. Integral trip unit for thermal and magnetic overload protection on MCCB.
- 2** Main bus connection studs enclosed with hinged transparent cover for easy access and operator safety.
- 3** Cover for bus studs includes safety lockout feature to keep unit from operating with door open.

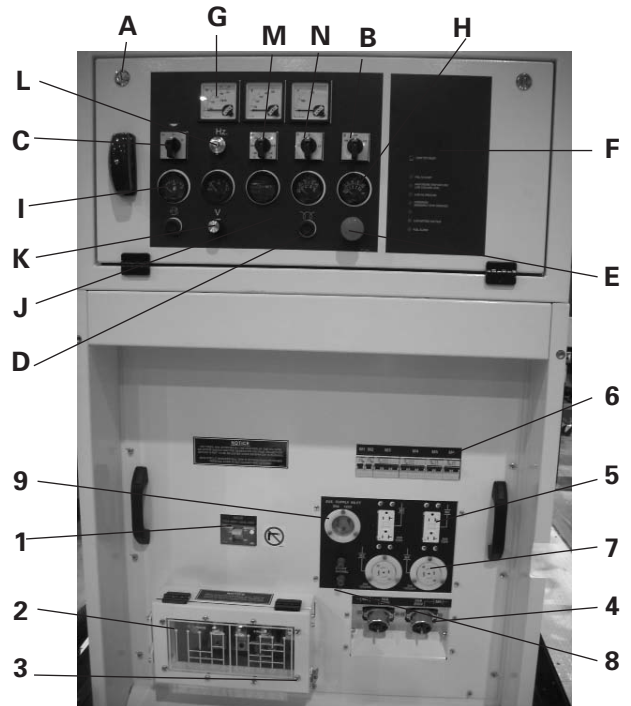

- 4** 2 — Single phase — California style Twistlocks, 50 Amps @ 208 Volt phase to phase, 120 Volt phase to neutral (adjustable to 240/139) or 240/120 single phase when operating in single phase voltage position.
- 5** 2 — Single phase — GFCI Duplex receptacles, 20 Amps @ 120 Volts.***
- 6** Individual circuit breaker protection for receptacles. Also act as on/off switches.
- 7** 2 — 3-phase NEMA locking receptacles, 20 Amps at 208/120V
- 8** Two wire remote start connection terminals.
- 9** 1 — 30A, 125V single phase NEMA locking inlet receptacle

*** Receptacles not for use with unit operating at 480/277V or 240/139V 3 phase.

Model	Length mm (in)	Width mm (in)	Height mm (in)	Weight	
				With Lube Oil and Coolant kg (lb)	With Fuel, Lube Oil and Coolant kg (lb)
XQ45	2900 (114.2)	1130 (44.5)	1800 (70.9)	1888 (4162)	2453 (5408)
XQ45 with trailer	4650 (183.1)	1943 (76.5)	2163.2 (85.3)	2479 (5465)	3044 (6711)

RATING DEFINITIONS

Standby – Applicable for supplying continuous electrical power (at variable load) in the event of a utility power failure. No overload is permitted on these ratings. The generator on the generator set is peak prime rated (as defined in ISO8528-3) at 30° C (86° F).

Prime – Applicable for supplying continuous electrical power (at variable load) in lieu of commercially purchased power. There is no limitation to the annual hours of operation and the generator set can supply 10% overload power for 1 hour in 12 hours.

STANDBY
PRIME
60 Hz

45 kW
41 kW

CATERPILLAR®

TOP VIEW

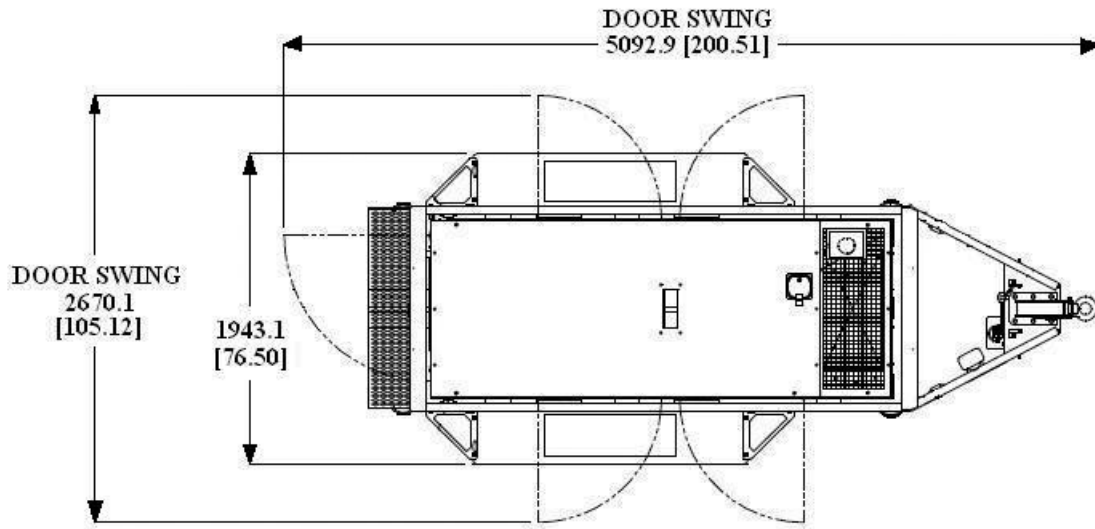

SIDE VIEW

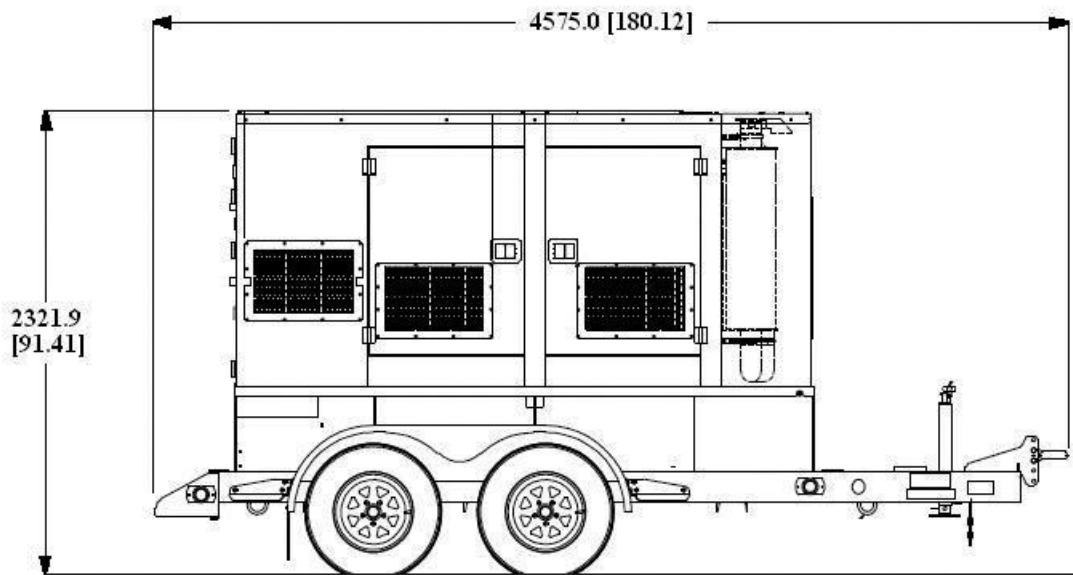

Information contained in this publication may be considered confidential.

Discretion is recommended when distributing.

Materials and specifications are subject to change without notice.

CAT, CATERPILLAR, their respective logos, "Caterpillar Yellow," the "Power Edge" trade dress, as well as corporate and product identity used herein, are trademarks of Caterpillar and may not be used without permission.

www.Cat-ElectricPower.com

Market: N. America

LEHE5175-03 (10-09)

© 2009 Caterpillar
All Rights Reserved.
Printed in U.S.A.