

# RECO

High Performance Rental Air Dryers

## RHA 1600 Desiccant Air Dryer

LOW PROFILE DESIGN - 3,500lbs



- Dual Tower Heatless Regenerative Base Dryer
- Adjustable Purge
- 1/8" Activated Alumina Desiccant Installed
- Coalescing Pre Filter Premium Grade With Installed Automatic Motorized Drain
- Particulate After Filter
- Pressure Guages
- High Performance Butterfly Valves
- Nema 4 Enclosure with Advanced Controls
- 115 Volt Receptacle Plug
- Forklift Slots on All Four Sides
- Reco Instruction Books/parts Lists
- Piping Design to Rear/ Bottom Of Skid 3" Npt
- Made In U.S.A. ASME Coded and Stamped Vessels with Relief Valves
- All Components Mounted, Wired, and Prepped

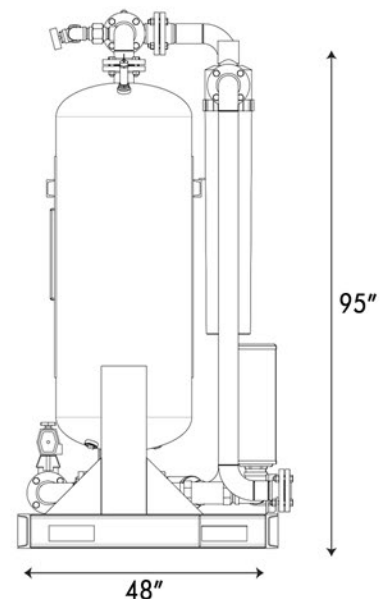
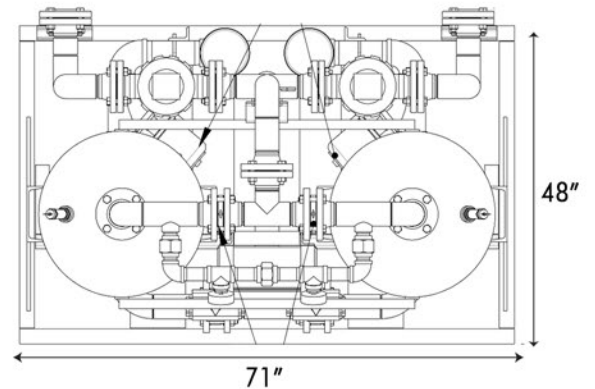
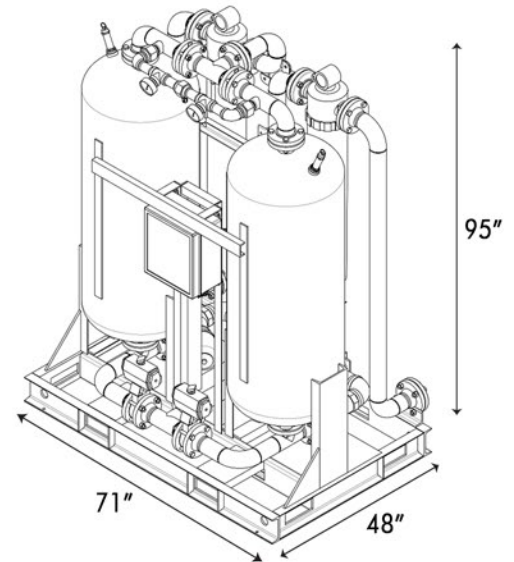

Please visit [www.RECOdryer.com](http://www.RECOdryer.com) for details and quotes!